

SECTION A/SE108  
[ E102 ]

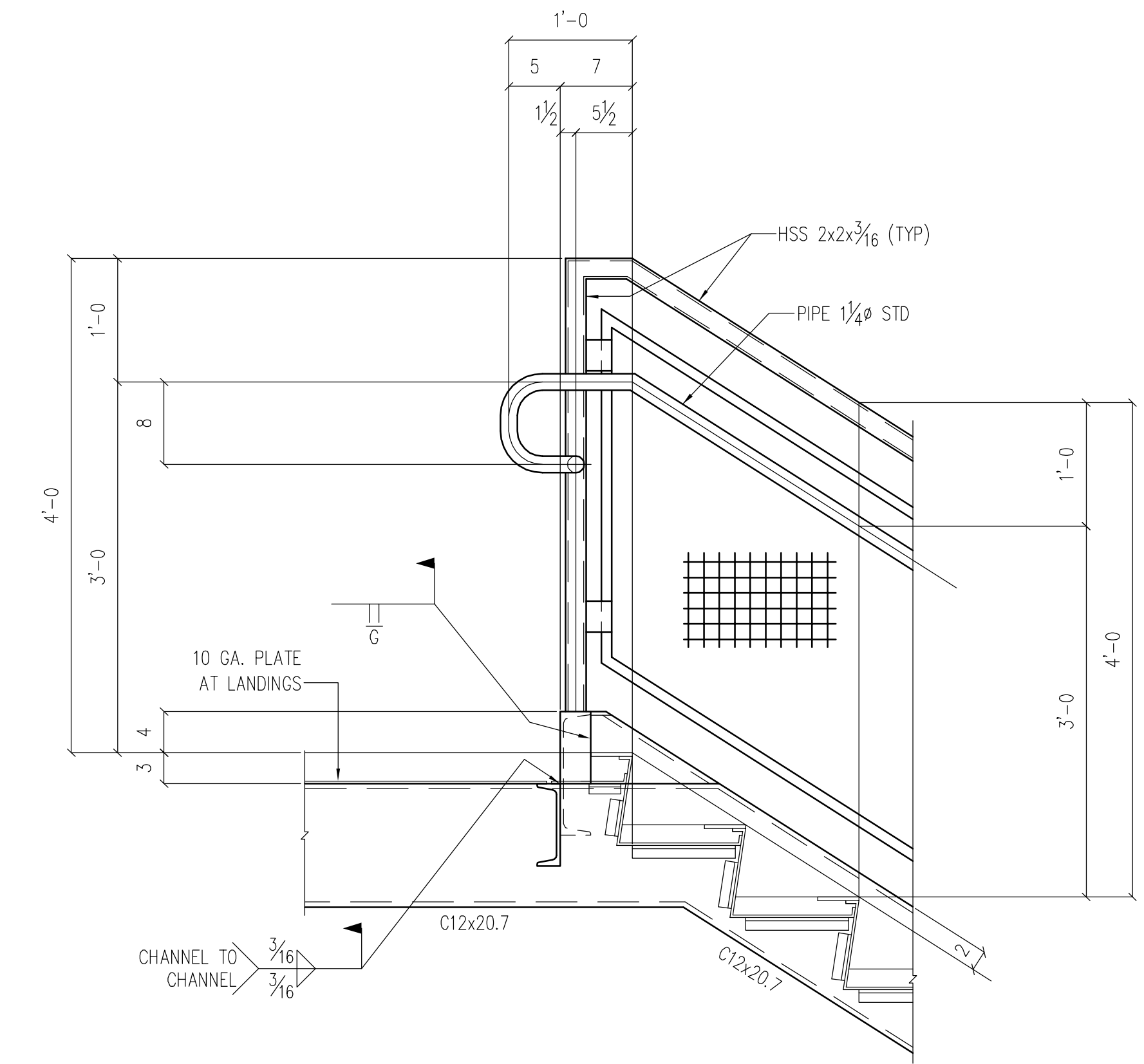

SECTION B/SE108  
[ SE102 ]

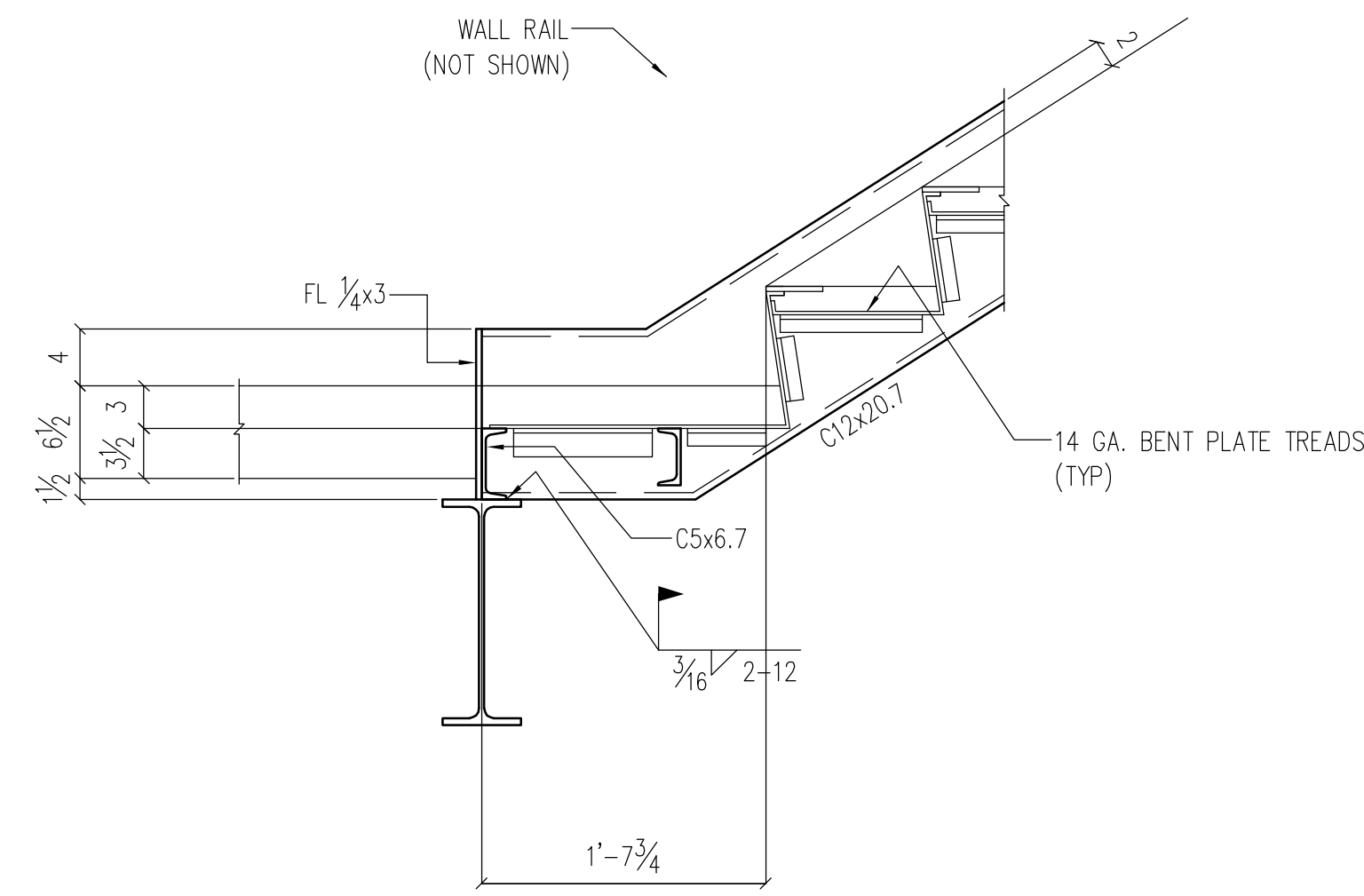

SECTION C/SE108  
[ SE101 ]

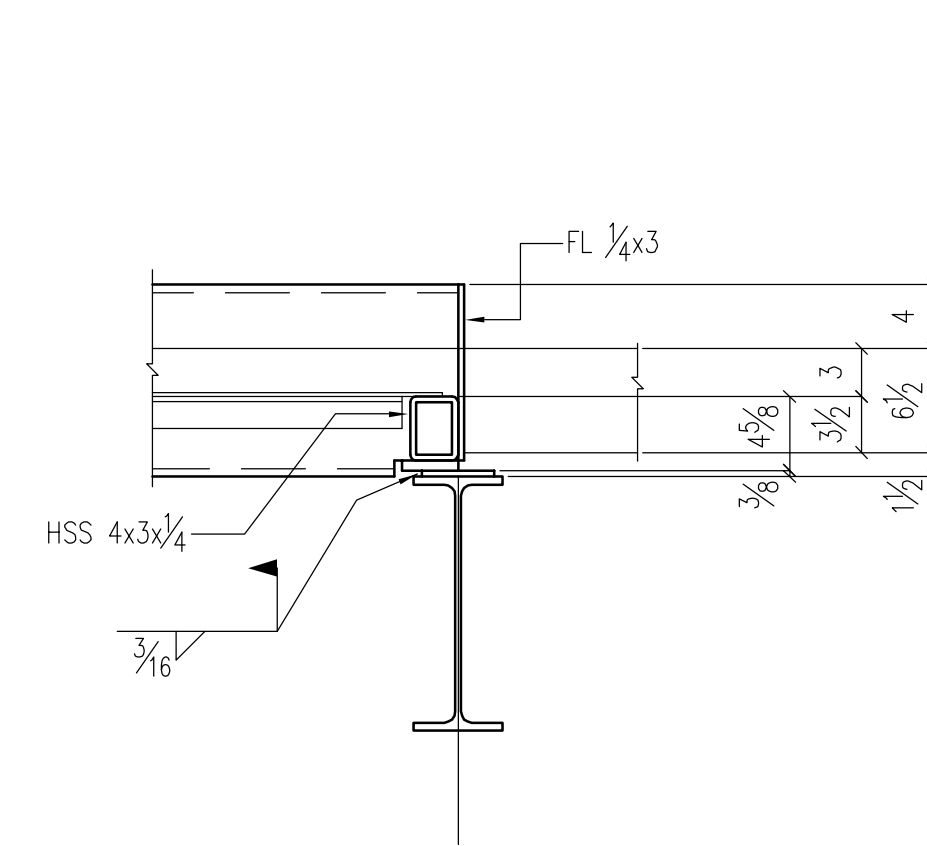

SECTION D/SE108  
[ SE101 ]

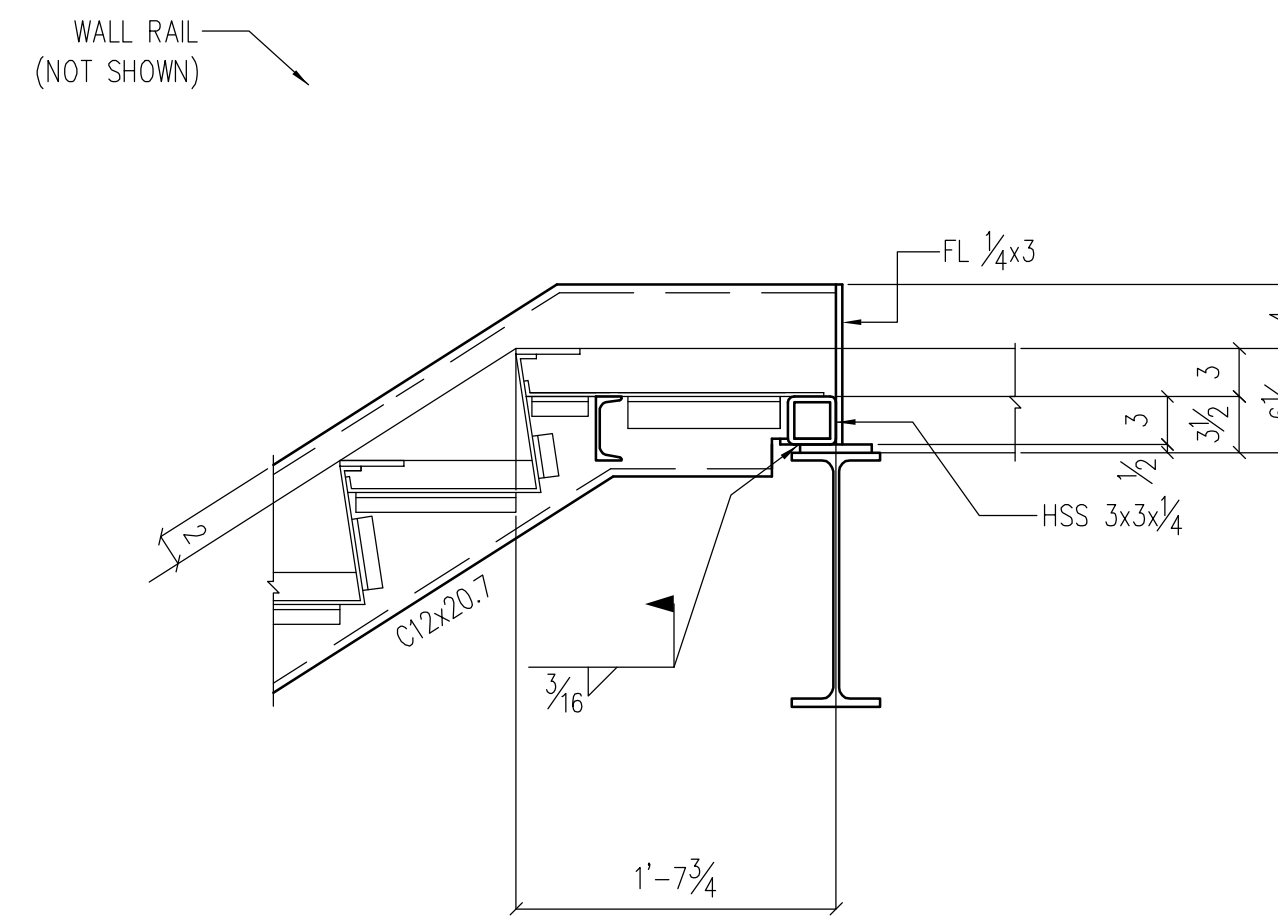

SECTION F/SE108  
[ SE102 ]

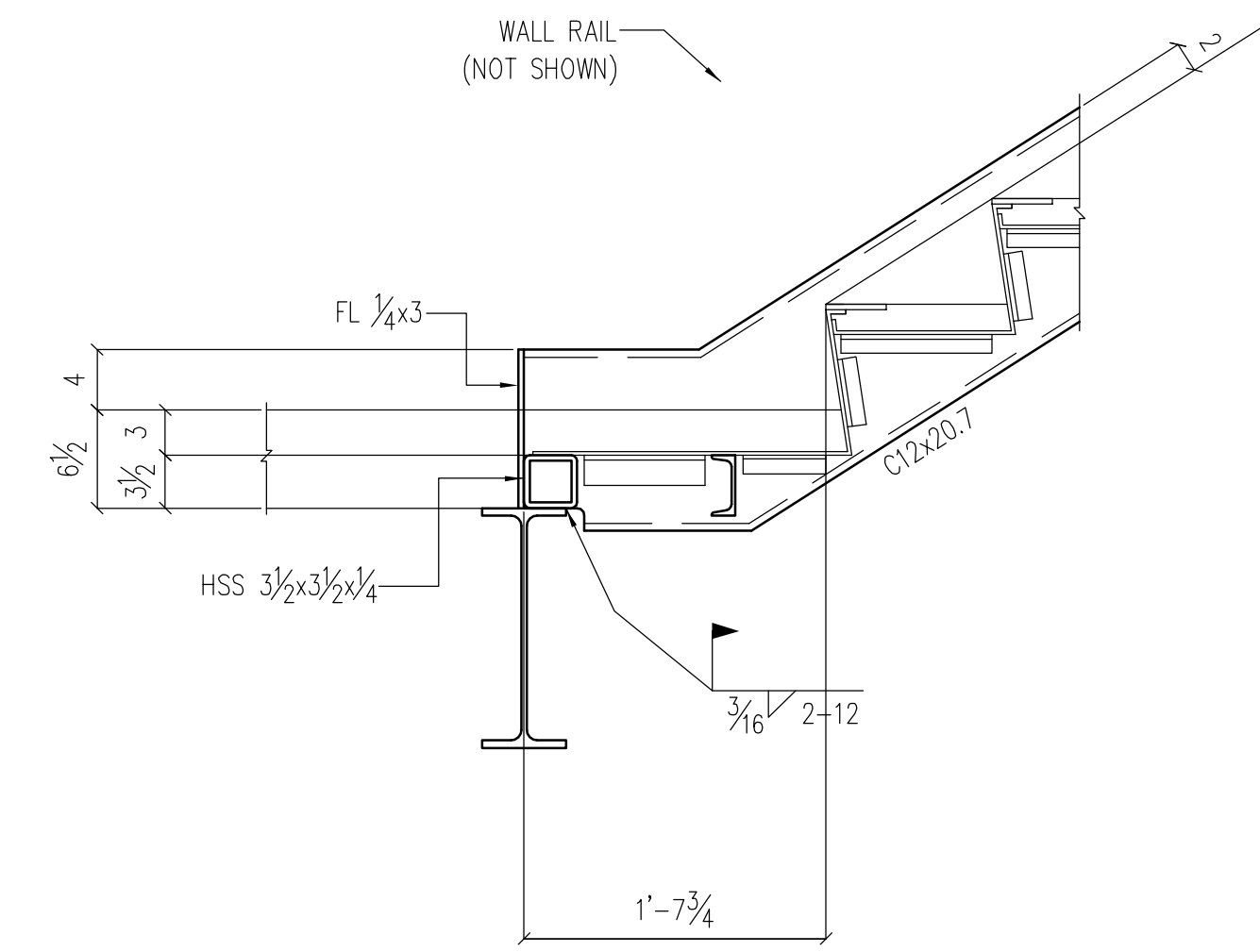

SECTION G/SE108  
[ SE102 ]

STAIR NO. 2 - AREA A

Rev.	Date	Description	By

**IRWIN STEEL**  
15740 Highway 114 ~ Justin, Texas 76247  
Phone (817) 636-2508 ~ Fax (817) 636-2506

REF: A702

PRINT RECORD					
Date	Quan.	For	Date	Quan.	For
DATE		APPROVAL			
DATE		FIELD USE			

Job Name: STANDARD PAN STAIR IN STEEL FRAME  
Location: CITY, TEXAS  
Customer: CONTRACTOR  
Architect: ARCHITECT

DRAWN: THX      JOB NO: 1138      SHEET NO: SE108  
CHECKED: HAL      CAD NO:      DATE: