

SECTION A-A/SE105 (STAIR NO. 2 - LOOKING SOUTH)
[SE101, SE102]

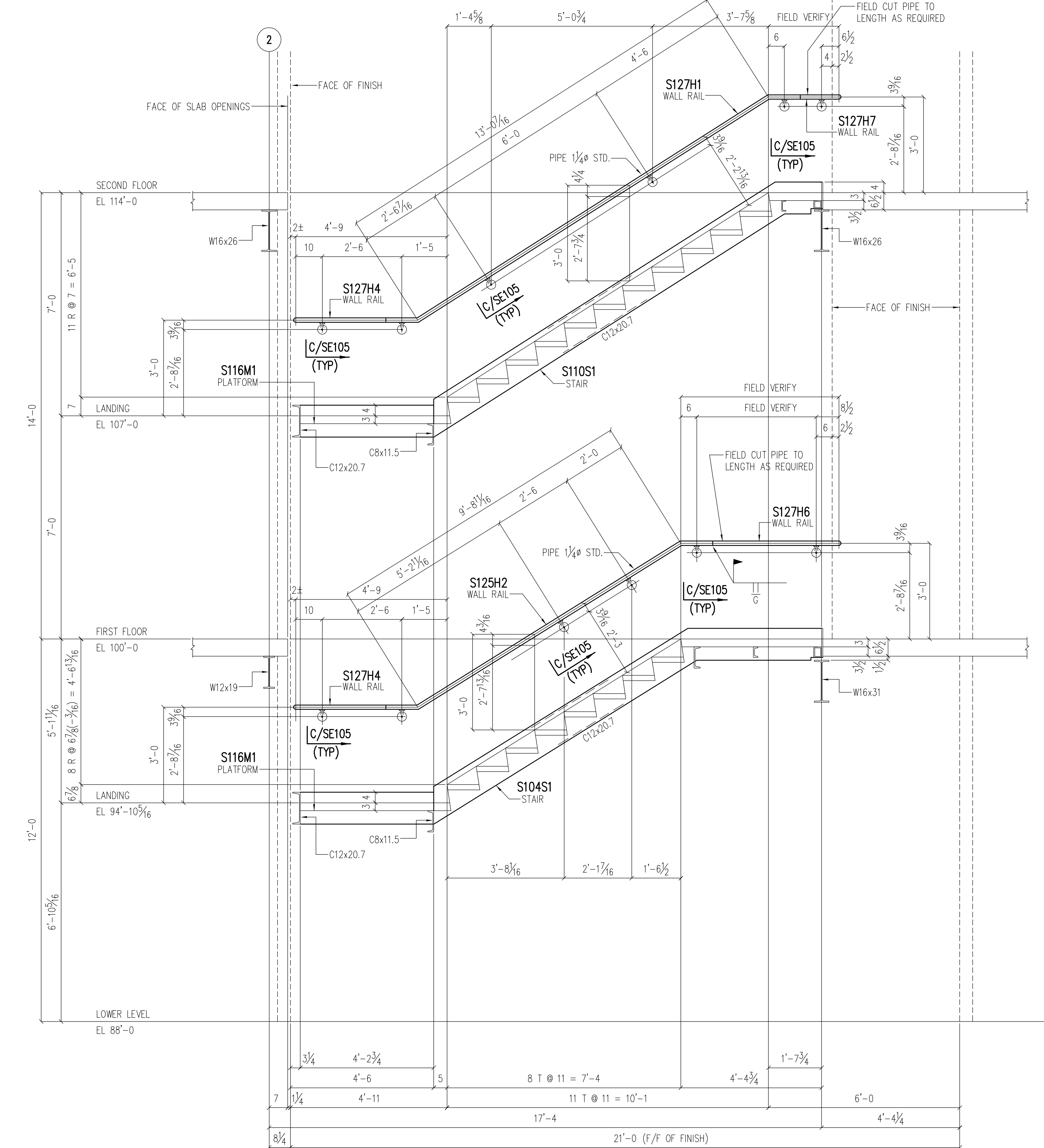

SECTION B-B/SE105 (STAIR NO. 2 - LOOKING NORTH)
[SE101, SE102]

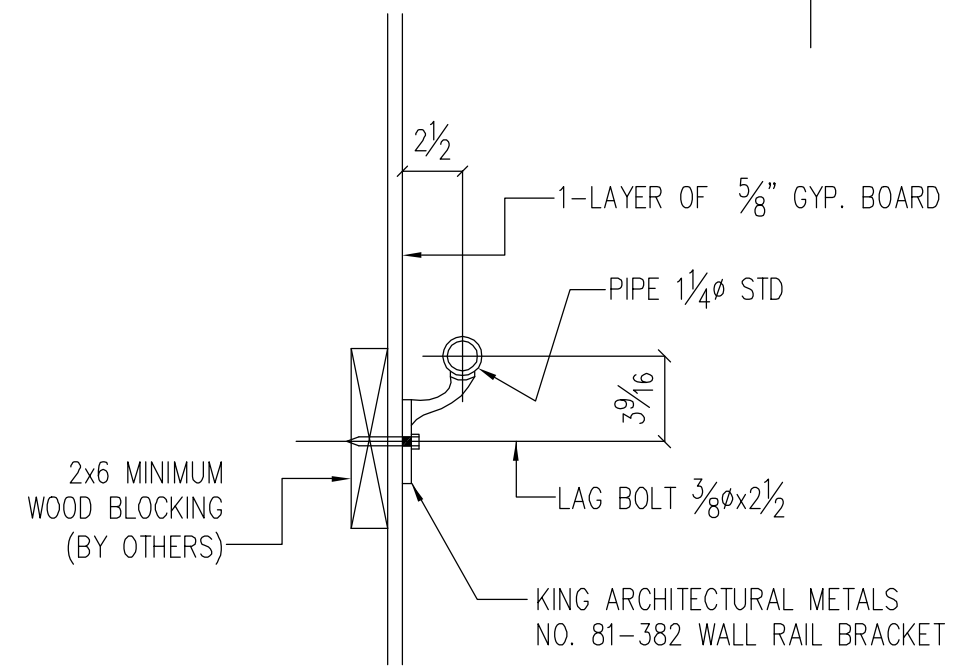

SECTION C-C/SE105
[SE105]

PRINT RECORD

Date	Quan.	For	Date	Quan.	For
DATE		APPROVAL			
DATE		FIELD USE			

STAIR NO. 2 - AREA A

Rev.	Date	Description	By

IRWIN STEEL
15740 Highway 114 ~ Justin, Texas 76247
Phone (817) 636-2508 ~ Fax (817) 636-2506

Job Name: STANDARD PAN STAIR IN STEEL FRAME
Location: CITY, TEXAS
Customer: CONTRACTOR
Architect: ARCHITECT

REF: A702
DRAWN: THX
CHECKED: HAL
JOB NO: 1138
CAD NO:
SHEET NO: SE105